

4

3

2

1

TUBING			
ITEM	QTY	DESCRIPTION	MATERIAL
A	2	LOWER LINK	36 - 2.0 X .250 STEEL DOM ROUND TUBING
B	1	UPPER LINK	26 - 1.75 X .120 STEEL DOM ROUND TUBING
C	1	UPPER LINK INNER TUBE	6 - 1.5 X .250 STEEL DOM ROUND TUBING
D	1	PANHARD LINK	36 - 1.5 X .250 STEEL DOM ROUND TUBING

JOINTS		
ITEM	QTY	DESCRIPTION
E	2	SUMMIT FLEX JOINT - RIGHT HAND THREAD
F	3	SUMMIT FLEX JOINT - LEFT HAND THREAD
G	2	7/8 RSMX12 HEIM JOINT - RIGHT HAND THREAD
H	1	7/8 RSMX12 HEIM JOINT - LEFT HAND THREAD

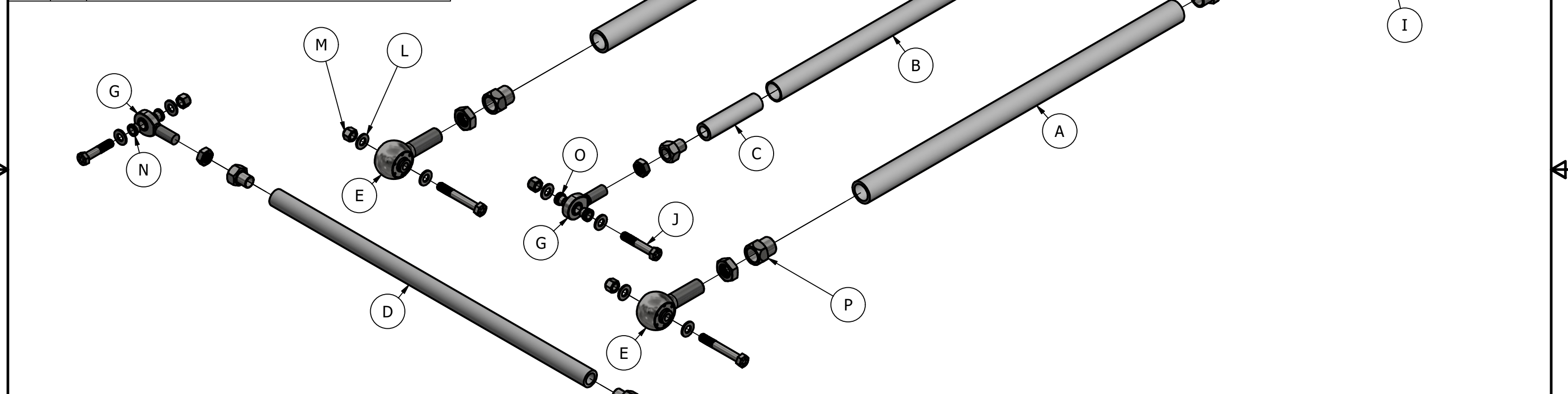

HARDWARE		
ITEM	QTY	DESCRIPTION
I	5	5/8 X 4.5 BOLT
J	3	5/8 X 3.5 BOLT
L	16	5/8 SAE WASHER
M	8	5/8 NUT
N	2	1.5" MISALIGNMENT SPACER (7/8 OD, 5/8 ID)
O	2	1.2" MISALIGNMENT SPACER (7/8 OD, 5/8 ID)
P	5	TUBE ADAPTER (1.5 OD, 1.25 ID)
Q	3	TUBE ADAPTER (1 OD, .875 ID)

DRAWN
 NICK BARSALOU 10/15/2022

PROPRIETARY AND CONFIDENTIAL

THE INFORMATION CONTAINED IN THIS DRAWING IS THE SOLE PROPERTY OF **4 WHEEL UNDERGROUND**. ANY REPRODUCTION IN PART OR IN WHOLE WITHOUT THE WRITTEN PERMISSION OF **4 WHEEL UNDERGROUND** IS PROHIBITED

DIMENSIONS ARE IN INCHES
 TOLERANCES:
DECIMAL ± .010"
BEND ± 1°

4 WHEEL UNDERGROUND

DESCRIPTION
FRONT 3-LINK SYSTEMS

SIZE B	PART NUMBER	REV
SCALE .13	SHEET 1 OF 1	

4

3

2

1